

BATTERY REPLACEMENT

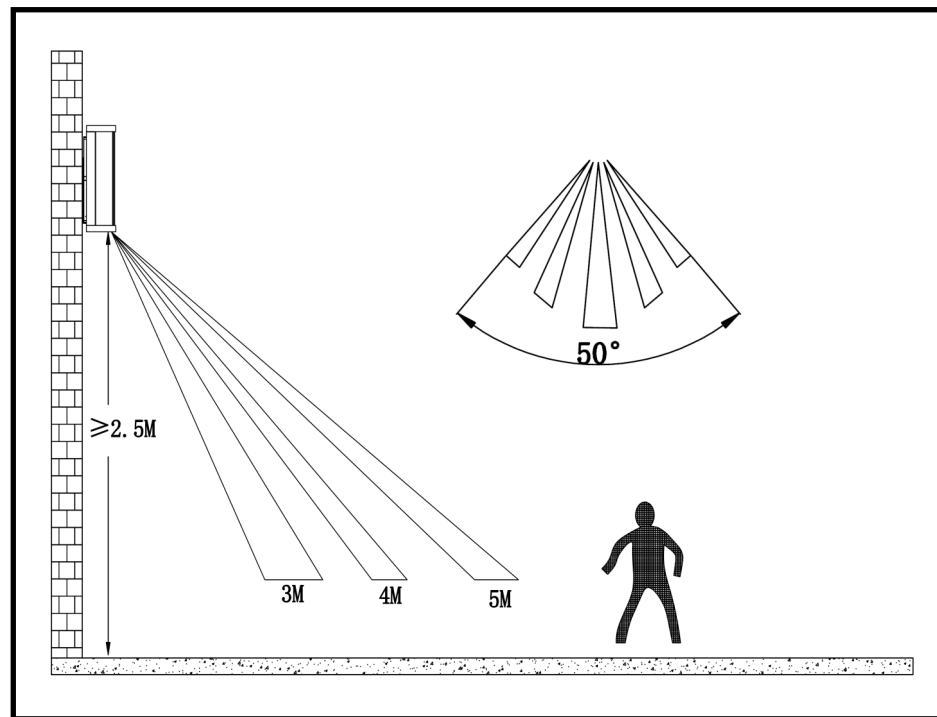
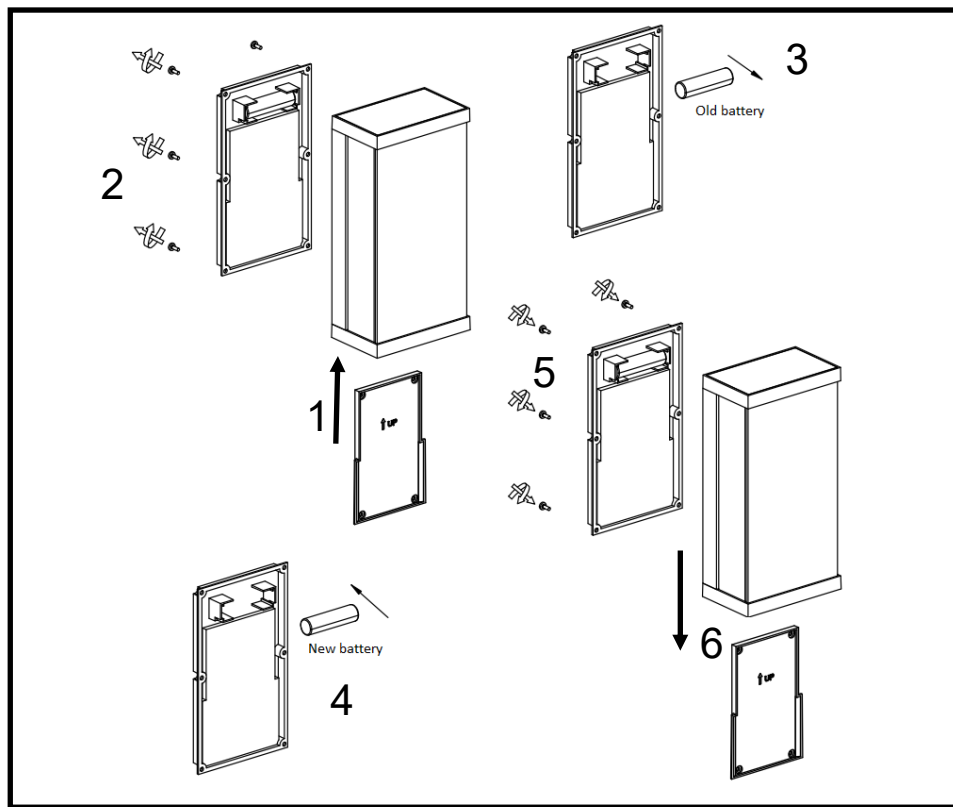

Instruction for the solar lamp

- * We recommend this product is installed by a competent person.
 - * This product is rated IP54 and is suitable for outdoor use when fitted in accordance with these instructions
 - * To avoid damage to concealed wiring during installation, establish the direction of any wires that might be located under mounting surface before drilling fixing holes.
 - * **IMPORTANT:** this product does not require any external wiring.
- The solar voltaic cell and PIR sensor are fixed, we recommend that it is installed in an open area that is not shaded by trees.

Note: The solar voltaic cell and PIR sensor should be cleaned on a regular bases with a soft cloth. Charge the fitting under sunlight for 3 days before use.

Mode 1: Depress button for 1.2 second to turn LED light on, this will illuminate the LED at 10% of its output when the ambient light level is below 20 lux. When the PIR detects movement of a warm object, the lamp will illuminate at 100% brightness for the duration of movement being detected. Once movement ceases the light will drop back to 10% brightness. After 5 hours of operation with the light level below 20 lux, the light will reduce the LED brightness to 5% and at detection of movement, the output will be reduced to 70%. The fitting will turn off once the ambient light level is above 20 lux.

Stainless steel/aluminium enjoys a strong and enduring reputation for long term appearance and structural integrity. But like all materials they may become stained or discoloured over time, impairing the overall look. This brown discoloration is referred to as "tea staining". Tea staining can be defined as: Discoloration of the surface of stainless steel/aluminium that does not affect the structural integrity or the longevity of the material.

CONTRIBUTING FACTORS: The relationships between the contributing factors are complex, but generally become increasingly critical closer to marine environments.

ENVIRONMENTAL FACTORS: Tea staining occurs most commonly within 5 miles of the sea and becomes progressively worse closer to the marine source. However, wind exposure, pollution levels and higher temperatures can create environments where tea staining may occur outside the 5 mile limit. Therefore we recommend not to place this product within 5 miles of the sea/estuary.

MAINTENANCE: As with most outdoor products occasional maintenance is required to ensure protection from the elements. We would advise that fine grade oil (Such as 'Baby Oil' or WD40) is rubbed into the metal sections of the product. Regular treatment should aid the life and appearance of the product.

GUARANTEE: We will not assume responsibility for corrosion or any other resulting damage to our products where they are installed in areas in which fertilizers or salt are present, either in the air or in the soil, or where our products are installed near to chemical plants etc. with emissions of heavily polluted air.

Mode 2: Depress button for 1 second to change to mode 2.

Important note - In mode 2 the PIR sensor is deactivated so the fitting will not react to detection of movement. The LED will illuminate at 50% of its output when the ambient light level is below 20 lux. After 2 hours of operation this will reduce to 30% and after 5 hours of operation it will reduce to 20%. The fitting will turn off once the ambient light level is above 20 lux.

Mode 3: Depress button for 1 second to change to mode 3.

The fitting will not illuminate at all when the ambient light levels drop to 20 lux. The fitting will illuminate at 100% when movement is detected and remain lit for 25 secs after movement ceases. After 5 hours of operation with the ambient level below 20 lux, the output will reduce to 70% on detection of movement and will remain lit for 25 secs after movement ceases. The fitting will turn off once the ambient light level is above 20 lux.

